



# Electric three-wheel counterbalance forklift truck

## **EFG 213-220**

Lift height: 2020-7000 mm / Load capacity: 1300-2000 kg

# EFG 213-220

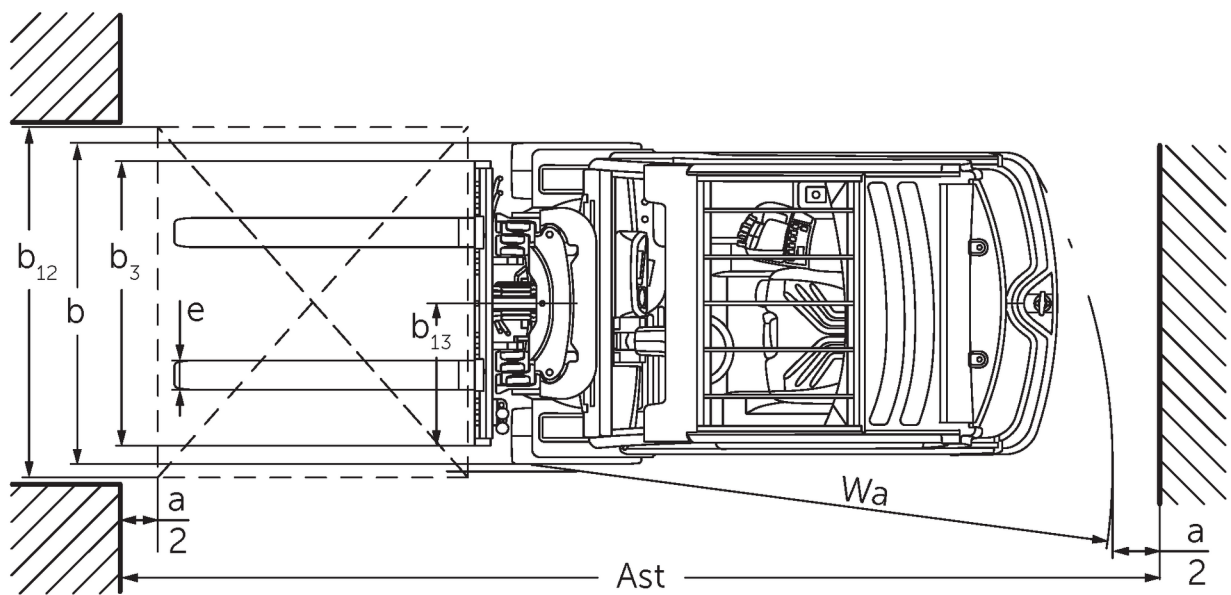
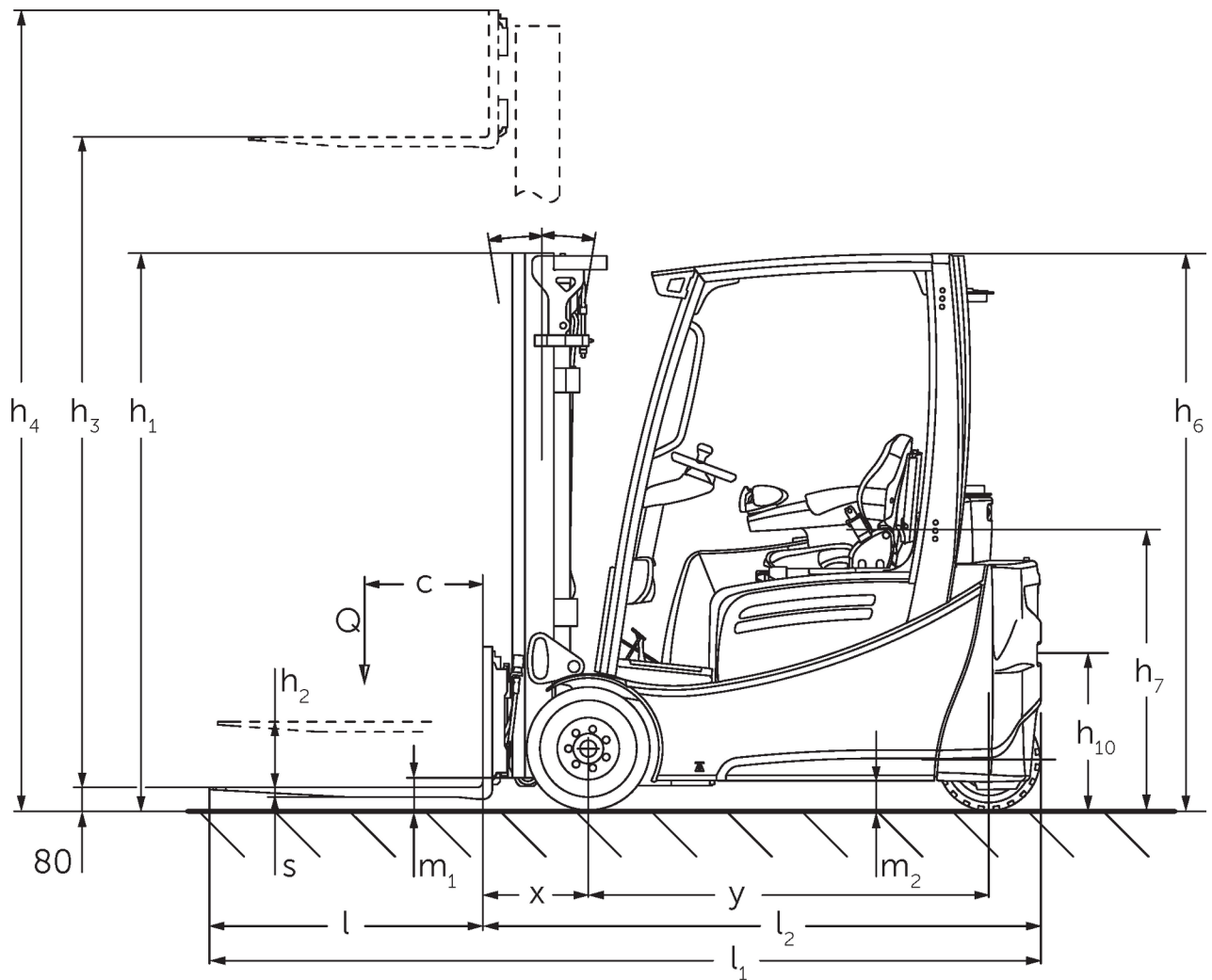

# EFG 213-220

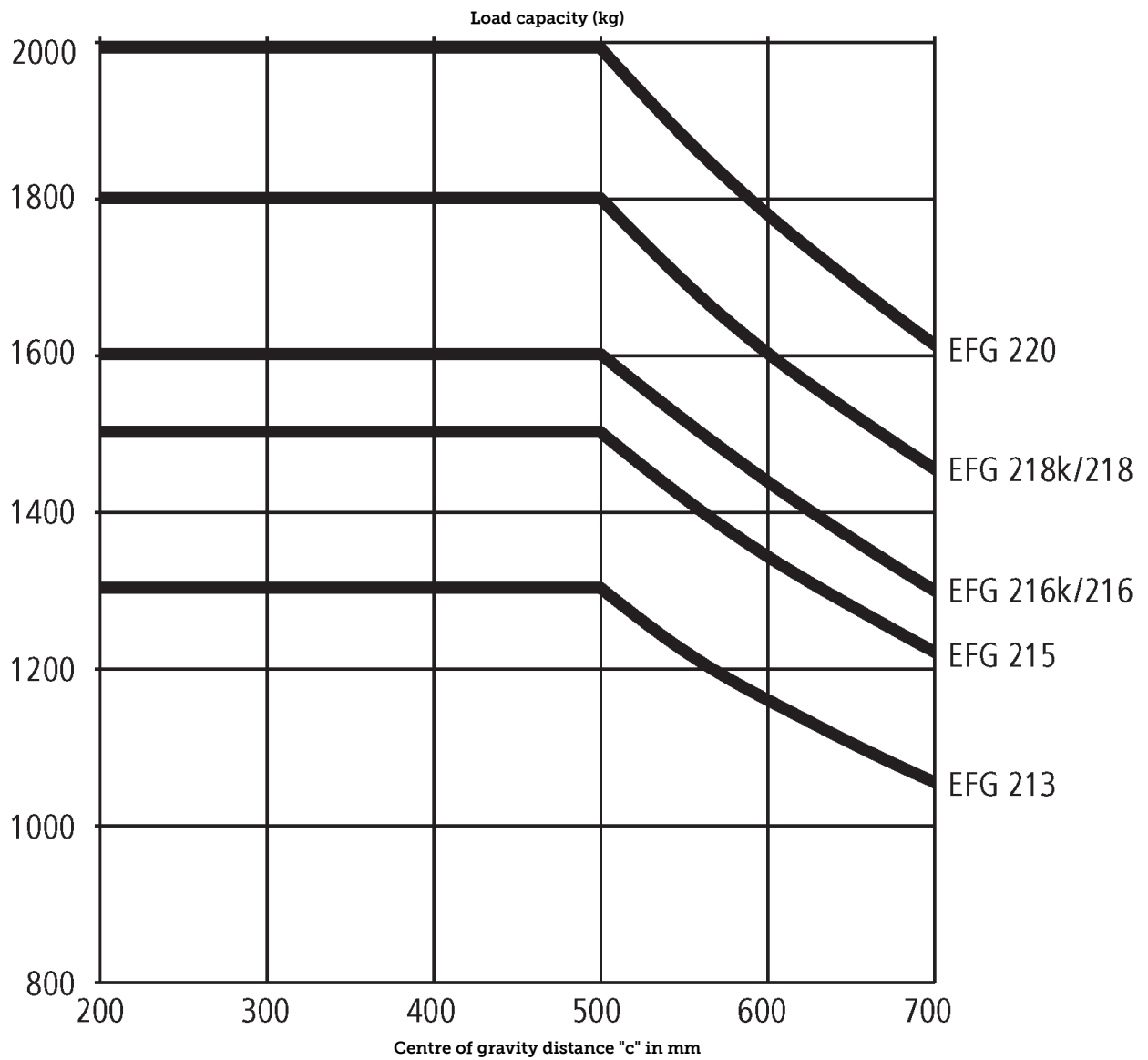

# EFG 213-220

EFG 213, EFG 215, EFG 216k, EFG 216	Lift (h3)	Retracted mast height (h1)	Free lift (h2)	Extended mast height (h4)	Forward/backward tilt of mast
Duplex mast ZT	<b>3000 mm</b>	<b>2060 mm</b>	<b>150 mm</b>	<b>3590 mm</b>	<b>7 / 6 °</b>
	3100 mm	2110 mm	150 mm	3690 mm	7 / 6 °
	3300 mm	2210 mm	150 mm	3890 mm	7 / 7 °
	3500 mm	2310 mm	150 mm	4090 mm	7 / 7 °
	3700 mm	2410 mm	150 mm	4290 mm	7 / 7 °
	4000 mm	2560 mm	150 mm	4590 mm	7 / 7 °
	4500 mm	2810 mm	150 mm	5090 mm	7 / 7 °
Duplex mast ZZ	<b>2900 mm</b>	<b>1965 mm</b>	<b>1375 mm</b>	<b>3490 mm</b>	<b>7 / 6 °</b>
	3100 mm	2065 mm	1475 mm	3690 mm	7 / 6 °
	3180 mm	2105 mm	1515 mm	3770 mm	7 / 7 °
	3300 mm	2165 mm	1575 mm	3890 mm	7 / 7 °
	3500 mm	2265 mm	1675 mm	4090 mm	7 / 7 °
	3700 mm	2365 mm	1775 mm	4290 mm	7 / 7 °
	4000 mm	2515 mm	1925 mm	4590 mm	7 / 7 °
Triplex mast DZ	<b>4250 mm</b>	<b>1975 mm</b>	<b>1385 mm</b>	<b>4840 mm</b>	<b>7 / 4 °</b>
	4400 mm	2025 mm	1435 mm	4990 mm	7 / 4 °
	4640 mm	2105 mm	1515 mm	5230 mm	7 / 5 °
	4700 mm	2125 mm	1535 mm	5290 mm	7 / 5 °
	4800 mm	2165 mm	1575 mm	5390 mm	7 / 5 °
	5000 mm	2235 mm	1645 mm	5590 mm	7 / 5 °
	5500 mm	2415 mm	1825 mm	6090 mm	7 / 5 °
	6000 mm	2585 mm	1995 mm	6590 mm	7 / 5 °
	6500 mm	2765 mm	2175 mm	7090 mm	7 / 5 °
	7000 mm	2935 mm	2345 mm	7590 mm	7 / 5 °
EFG 218k, EFG 218, EFG 220	Lift (h3)	Retracted mast height (h1)	Free lift (h2)	Extended mast height (h4)	Forward/backward tilt of mast
Duplex mast ZT	<b>2020 mm</b>	<b>1577 mm</b>	<b>150 mm</b>	<b>2632 mm</b>	<b>7 / 5 °</b>
	3000 mm	2067 mm	150 mm	3612 mm	7 / 6 °
	3100 mm	2117 mm	150 mm	3712 mm	7 / 6 °
	3300 mm	2217 mm	150 mm	3912 mm	7 / 7 °
	3500 mm	2317 mm	150 mm	4112 mm	7 / 7 °
	3700 mm	2417 mm	150 mm	4312 mm	7 / 7 °
	4000 mm	2567 mm	150 mm	4612 mm	7 / 7 °
	4500 mm	2817 mm	150 mm	5112 mm	7 / 7 °
Duplex mast ZZ	<b>2900 mm</b>	<b>1972 mm</b>	<b>1330 mm</b>	<b>3542 mm</b>	<b>7 / 6 °</b>
	3100 mm	2072 mm	1430 mm	3742 mm	7 / 6 °
	3180 mm	2112 mm	1470 mm	3822 mm	7 / 7 °
	3300 mm	2172 mm	1530 mm	3942 mm	7 / 7 °
	3500 mm	2272 mm	1630 mm	4142 mm	7 / 7 °
	3700 mm	2372 mm	1730 mm	4342 mm	7 / 7 °
Triplex mast DZ	<b>4250 mm</b>	<b>1982 mm</b>	<b>1340 mm</b>	<b>4892 mm</b>	<b>7 / 6 °</b>
	4400 mm	2032 mm	1390 mm	5042 mm	7 / 6 °
	4640 mm	2112 mm	1470 mm	5282 mm	7 / 5 °
	4700 mm	2132 mm	1490 mm	5342 mm	7 / 5 °
	4800 mm	2172 mm	1530 mm	5442 mm	7 / 5 °

5000 mm	2242 mm	1600 mm	5642 mm	7 / 5 °
5500 mm	2422 mm	1780 mm	6142 mm	7 / 5 °
6000 mm	2592 mm	1950 mm	6642 mm	7 / 5 °
6500 mm	2772 mm	2130 mm	7142 mm	7 / 5 °
7000 mm	2942 mm	2300 mm	7642 mm	7 / 5 °

# VDI table

Stand-on: 09/2023

Characteristic	1.1	Manufacturer (abbreviated description)	Jungheinrich							
			EFG 213	EFG 215	EFG 216k	EFG 216	EFG 218k	EFG 218	EFG 220	
	1.2	Manufacturer's type designation								
	1.3	Drive	Electric							
	1.4	Operation	Seat							
	1.5	Load capacity/load	Q kg	1300	1500	1600	1800	2000		
	1.6	Load centre distance	c mm	500						
	1.8	Load distance, centre of drive axle to fork	x mm	344			364			
	1.9	Wheelbase	y mm	1249	1357	1465	1357	1465		
Weights	2.1.1	Service weight (incl. battery)	kg	2692	2937	2959	3018	3240	3191	3366
	2.2	Axle load laden front/rear	kg	3534 / 458	3860 / 577	4043 / 516	4050 / 566	4457 / 583	4477 / 514	4784 / 582
	2.3	Axle load unladen front/rear	kg	1307 / 1385	1290 / 1647	1392 / 1567	1479 / 1539	1403 / 1817	1534 / 1657	1514 / 1852
Wheels/suspension system	3.1	Tyres	Super-elastic (SE)							
	3.2	Tyre size, front	18 x 7-8				200 / 50-10			
	3.3	Tyre size, rear	140 / 55-9							
	3.5	Wheels, number front/back (x=driven)	2x/2							
	3.6	Tread width, front	b10 mm	904			914			
	3.7	Tread width, rear	b11 mm	176						
	Basic dimensions	4.1	Forward/backward tilt of mast	a/β °	7 / 6					
4.2		Retracted mast height (h1)	h1 mm	2060			2067			
4.3		Free lift (h2)	h2 mm	150						
4.4		Lift (h3)	h3 mm	3000						
4.5		Extended mast height (h4)	h4 mm	3590			3612			
4.7		Height of overhead guard (cab)	h6 mm	2040						
4.8		Seat height/stand height	h7 mm	920						
4.12		Coupling height	h10 mm	560						
4.19		total length	l1 mm	2933	3041	3149	3061	3169		
4.20		Length including fork shank	l2 mm	1783	1891	1999	1911	2019		
4.21.1		total width	b1 mm	1060			1120			
4.22		Fork dimensions	s/ e/l mm	40 x 80 x 1150						40 x 100 x 1150
4.23		Fork carriage connection class		2A						
4.24		Fork carriage width	b3 mm	980						
4.31		Ground clearance laden under mast	m1 mm	97			105			
4.32		Ground clearance centre of wheelbase	m2 mm	100						
4.34.1		Aisle width (pallet 1000x1200 sideways)	Ast mm	3112	3220	3327	3238	3345		
4.34.2		Aisle width (pallet 800x1200 length)	Ast mm	3235	3343	3450	3362	3469		
4.35		Turning radius	Wa mm	1440	1548	1655	1548	1655		
4.36	Smallest pivot point distance	b13 mm	0							

Performance data	5.1	Travel speed laden/unladen	km/h	16 / 16						
	5.2	Lift speed laden/unladen	m/s	0.51 / 0.74			0.46 / 0.74		0.45 / 0.63	
	5.3	Lowering speed laden/unladen	m/s	0.55 / 0.55						
	5.5	Drawbar pull laden	N	2300	2200	2150	2100	2000		1900
	5.6	Max. drawbar pull laden/unladen	N	13000 / 11100	13000 / 10900	13000 / 12000	13000 / 12600	12500 / 12100	12500 / 12500	12300 / 12000
	5.7	Gradeability laden/unladen	%	7.6 / 12.5	7.3 / 12.3		7 / 11.5	6.2 / 10.7	5.9 / 10.5	5.7 / 10.4
	5.8	Max. gradeability laden/unladen	%	28 / 31	27 / 28	27 / 31	27 / 33	25 / 29	25 / 31	24 / 30
	5.9	Acceleration time laden/unladen	s	5.5 / 5.1	5.6 / 5.2	5.7 / 5.2		5.8 / 5.3		5.9 / 5.3
	5.10	Service brake		electric/mechanical						
	E-motor/Electronics	6.1	Drive motor, performance S2 60 min	kW	4.5					
6.1.1		2. Drive motor, performance S2 60 min	kW	4.5						
6.2		Lift motor, performance with S3	kW	11.5						
6.3		Battery according to DIN 43531/35/36		DIN 43531 A						
6.4		Battery voltage/nominal capacity	V / Ah	48 / 500		48 / 625	48 / 750	48 / 625	48 / 750	
6.5		Battery weight	kg	715		855	1025	855	1025	
6.6		Energy consumption according to VDI cycle	kWh/h	0						
6.6.1		Energy consumption according to EN cycle	kWh/h	3.5	3.7	3.9		4.1		4.5
6.6.2		CO2 equivalent as per EN 16796	kg/h	1.9	2	2.1		2.2		2.4
6.7		Throughput	t/h	105	111	113		126		140
6.8.1	Energy consumption with max. throughput	kWh/h	4.7	4.8	4.9		5.4		5.5	
Other	8.1	Type of drive control		Impulse/AC						
	10.1	Operating pressure for attachment	bar	230						
	10.2	Oil flow for attachments	l/min	27						
	10.7	Sound level as per EN12053, operator's ear	dB (A)	67						
	10.8	Trailer coupling, model/type DIN		DIN 15170 H						

- This data sheet according to VDI guideline 2198 only states the technical values of the standard truck. Different tyres, other masts, additional equipment etc. may result in different values.

- 6.6.1: 60 working cycles / h

The German production facilities in  
Norderstedt, Moosburg and Landsberg  
are certified as well as our Genuine Parts  
Center in Kaltenkirchen. ISO 9001  
ISO 14001

**JUNGHEINRICH**