

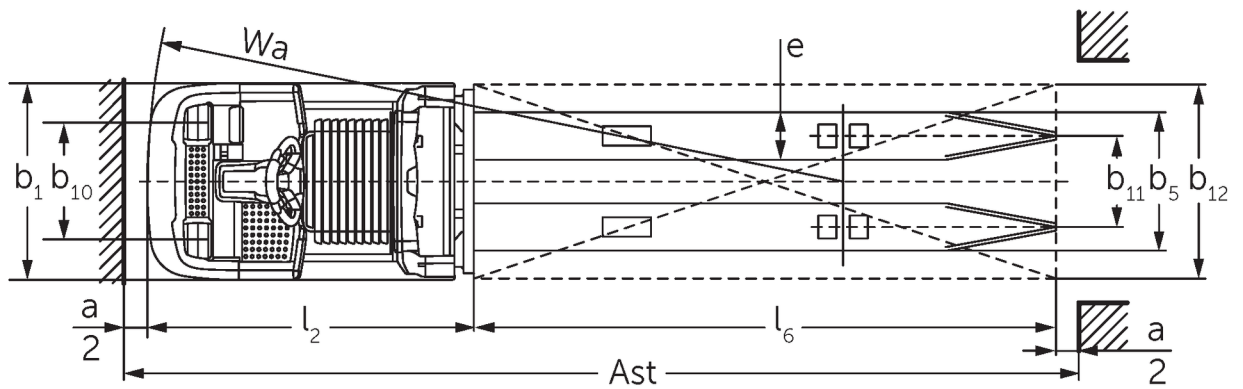

Low level order pickers **ECE 320**

Lift height: 750 mm / Load capacity: 2000 kg

ECE 320

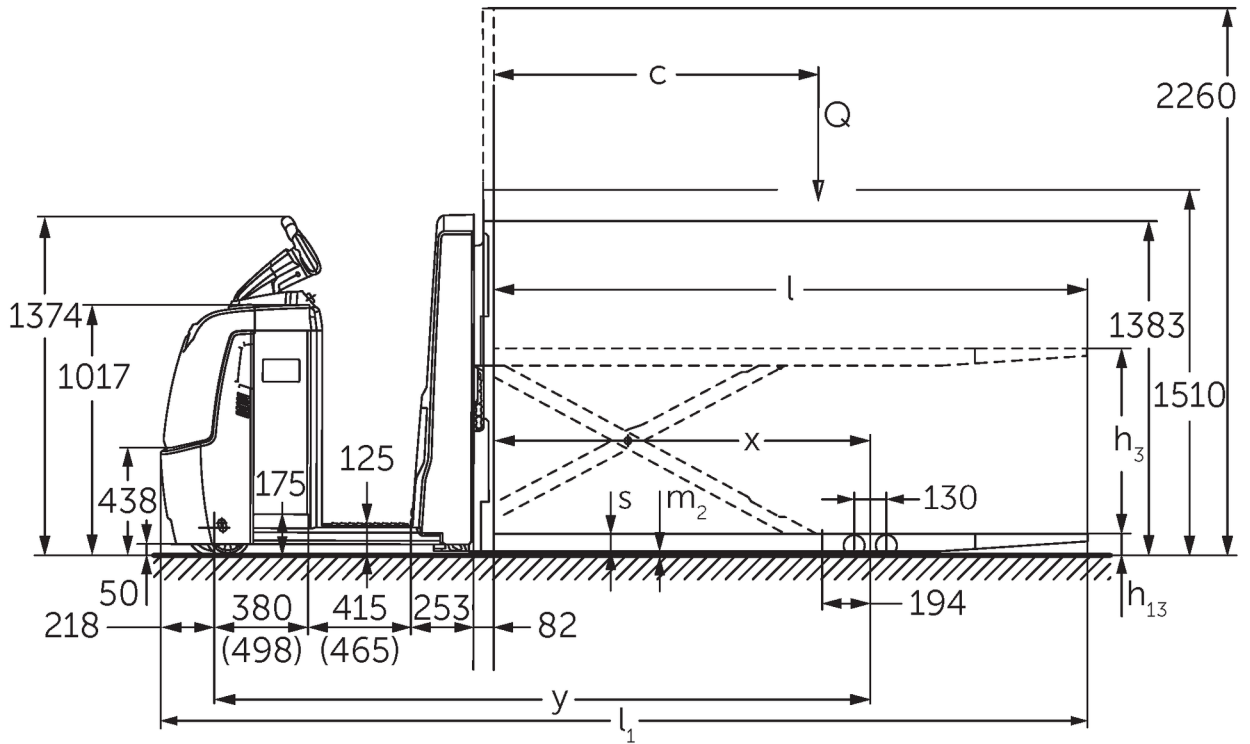

ECE 320

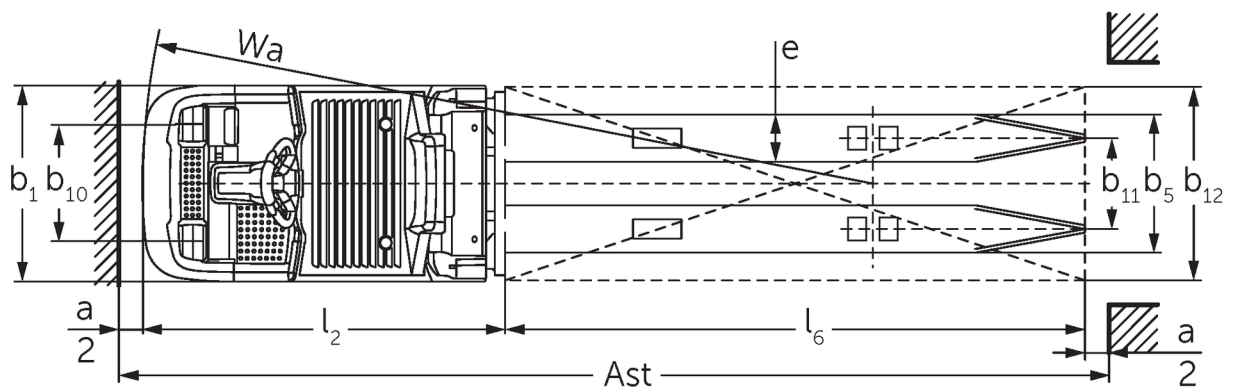
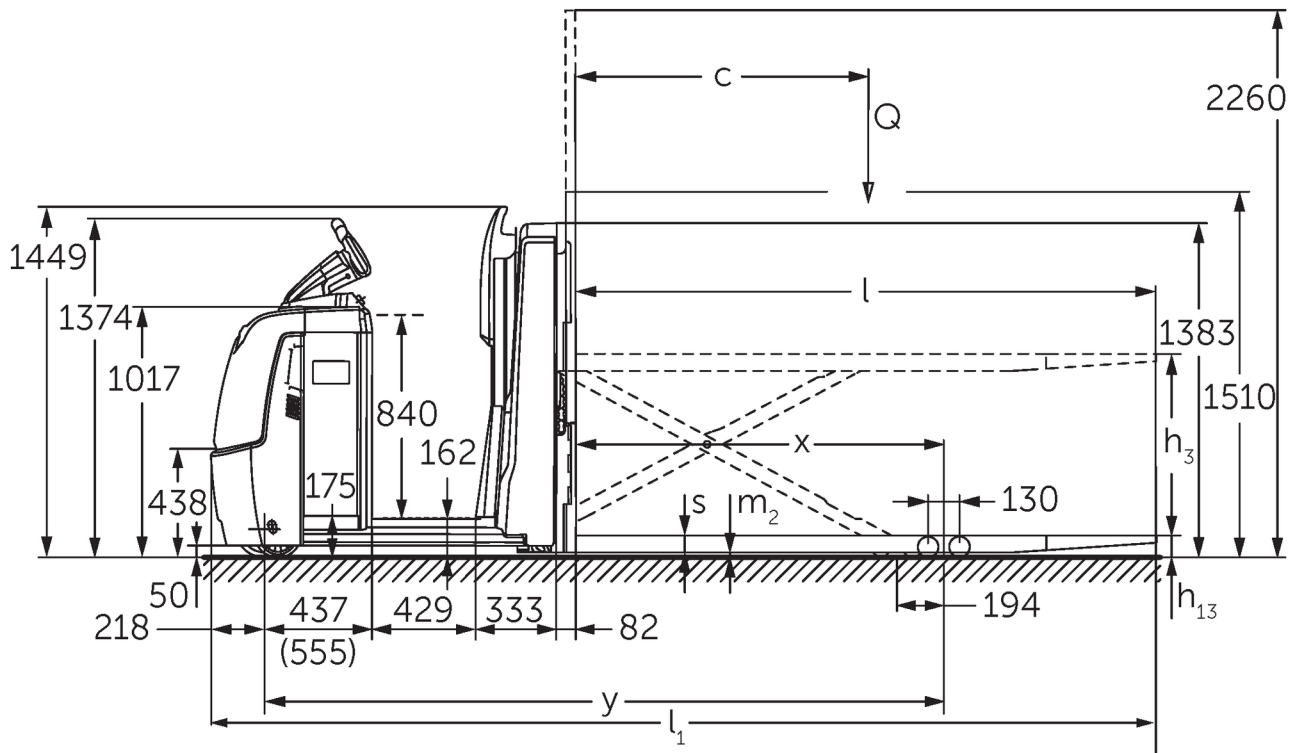

VDI table

Stand-on: 08/2022

Characteristic	1.1	Manufacturer (abbreviated description)		Jungheinrich	
	1.2	Manufacturer's type designation		ECE 320	ECE 320 HP
	1.3	Drive		Electric	
	1.4	Operation		Order pickers	
	1.5	Load capacity/load	Q kg	2000	
	1.6	Load centre distance	c mm	1200	
	1.8	Load distance, centre of drive axle to fork	x mm	1522	
	1.9	Wheelbase	y mm	2652	2803
	Weights	2.1.1	Service weight (incl. battery)	kg	1300
2.2		Axle load laden front/rear	kg	1120 / 2180	1240 / 2250
2.3		Axle load unladen front/rear	kg	900 / 400	1020 / 470
Wheels/suspension system	3.1	Tyres		Polyurethane (PU)	
	3.2	Tyre size, front		Ø 230 x 78	
	3.3	Tyre size, rear		Ø 85 x 85	
	3.4	Additional wheels		Ø 180 x 65	
	3.5	Wheels, number front/back (x=driven)		1+1x/4	
	3.6	Tread width, front	b ₁₀ mm	481	
	3.7	Tread width, rear	b ₁₁ mm	345	
	3.7.1	2. Tread width, rear	mm	375	
Basic dimensions	4.4	Lift (h ₃)	h ₃ mm	750	
	4.9	Height of tiller handle in drive position min./max.	mm	1374 / 1418	
	4.15	Height, lowered	h ₁₃ mm	90	
	4.19	Overall length	l ₁ mm	3747	3897
	4.20	Length including fork shank	l ₂ mm	1347	1497
	4.21.1	Overall width	b ₁ mm	810	
	4.22	Fork dimensions	s/e/l mm	70 x 195 x 2400	
	4.25	Width across forks	b ₅ mm	540	
	4.32	Ground clearance centre of wheelbase	m ₂ mm	20	
	4.34.2	Aisle width (pallet 800x1200 length)	Ast mm	3947	4097
	4.35	Turning radius	W _a mm	2869	3019
Performance data	5.1	Travel speed laden/unladen (Efficiency drivePLUS)	km/h	9.5 / 12.5 9.5 / 14	
	5.2	Lift speed laden/unladen	m/s	0.09 / 0.16	
	5.3	Lowering speed laden/unladen	m/s	0.11 / 0.11	
	5.8	Max. gradeability laden/unladen (Efficiency drivePLUS)	%	6 / 15 6 / 15	
	5.10	Service brake		generative	
E-motor/Electronics	6.1	Drive motor, performance S2 60 min (Efficiency drivePLUS)	kW	2.8 3.2	
	6.2	Lift motor, performance with S3	kW	1.5	
	6.4	Battery voltage/nominal capacity	V / Ah	24 / 465	
	6.5	Battery weight	kg	370	
	6.6.1	Energy consumption according to EN cycle (Efficiency PLUS)	kWh/h	0.6 0.63	
	6.6.2	CO2 equivalent as per EN 16796 (Efficiency PLUS)	kg/h	0.3 0.3	
	6.7	Throughput (Efficiency PLUS)	t/h	102 104	100 102
	6.8.1	Energy consumption with max. throughput (Efficiency PLUS)	kWh/h	1.52 1.72	1.53 1.72

Other	8.1	Type of drive control		AC
	10.5	Steering version		electric
	10.7	Sound level as per EN12053, operator's ear	dB (A)	62
<p>- This data sheet according to VDI guideline 2198 only states the technical values of the standard truck. Different tyres, other masts, additional equipment etc. may result in different values.</p>				

Efficiency: Values of standard package | PLUS: Values of performance package

Values for L battery compartment; standard stand-on platform and fork length 2,400 mm; lowered load section.

- VDI no. 1.8: with raised load section: x - 194 mm.

- VDI no. 1.9: with XL or XL (ERE) battery compartment: y + 118 mm; with extended stand-on platform: y + 50 mm; with lowered load section: y - 194 mm.

- VDI no. 4.19: with XL or XL (ERE) battery compartment: l1 + 118 mm; with extended stand-on platform: l1 + 50 mm.

- VDI no. 4.20: with XL or XL (ERE) battery compartment: l2 + 118 mm; with extended stand-on platform: l2 + 50 mm.

- VDI no. 4.34.2: with XL or XL (ERE) battery compartment: working aisle width (Ast) + 118 mm; with extended stand-on platform: working aisle width (Ast) + 50 mm; diagonal as per VDI: working aisle width (Ast) + 94 mm.

- VDI no. 4.35: with XL or XL (ERE) battery compartment: Wa + 118 mm; with extended stand-on platform option: Wa + 50 mm; with raised load section: y - 194 mm.

- VDI no. 6.2: with S3 10%.

- VDI no. 6.4: with XL battery compartment: 24 V / 620 Ah.

- VDI no. 6.5: with XL battery compartment: 460 kg.

The German production facilities in
Norderstedt, Moosburg and Landsberg
are certified.

ISO 9001
ISO 14001

Jungheinrich fork lift trucks meet
European safety requirements.



 **JUNGHEINRICH**

The Jungheinrich logo, featuring a red upward-pointing arrow above the word 'JUNGHEINRICH' in a bold, black, sans-serif font.