



Medium/high level order picker **EKS 110**

Lift height: 1000-2800 mm / Load capacity: 1000 kg

EKS 110

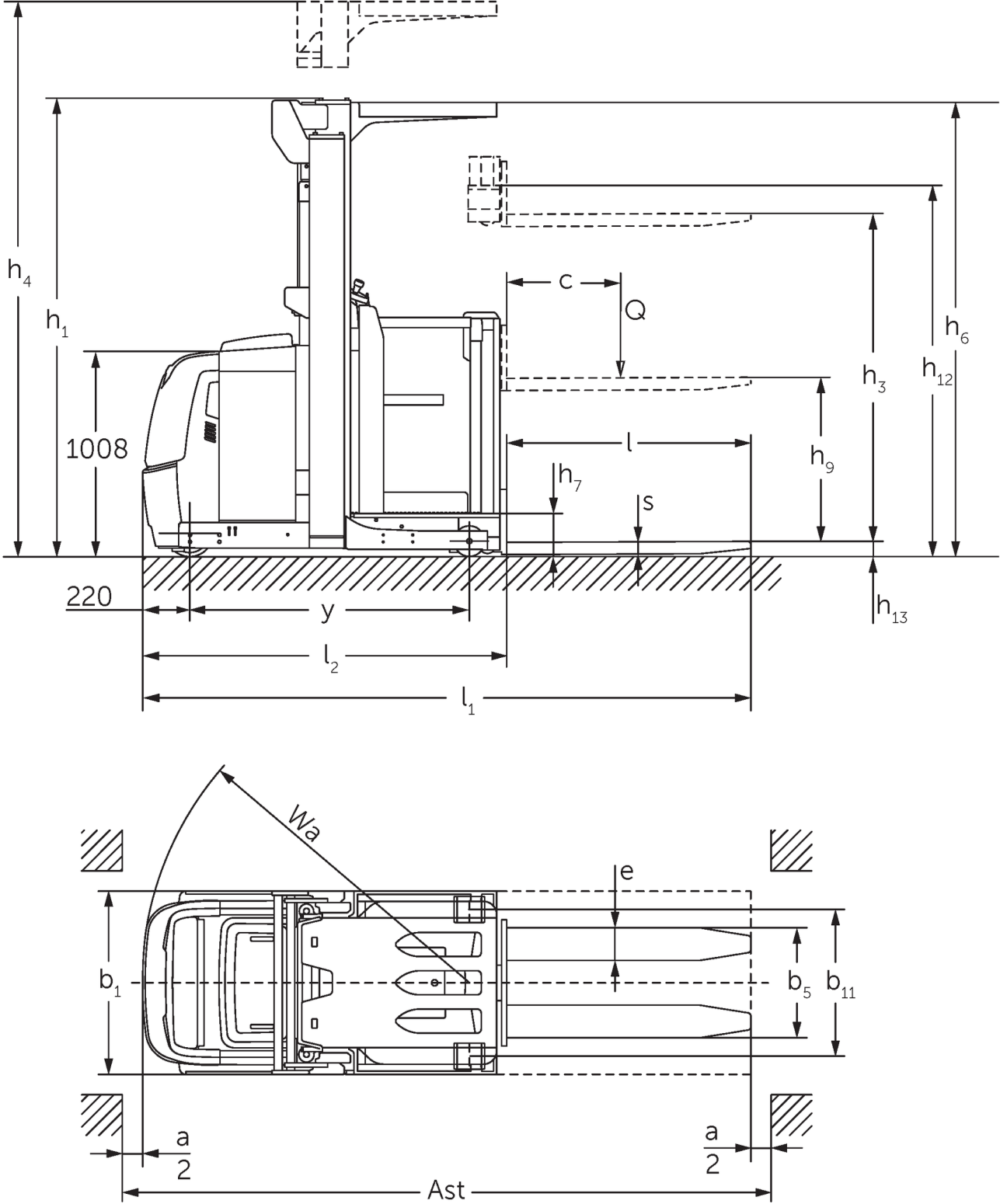
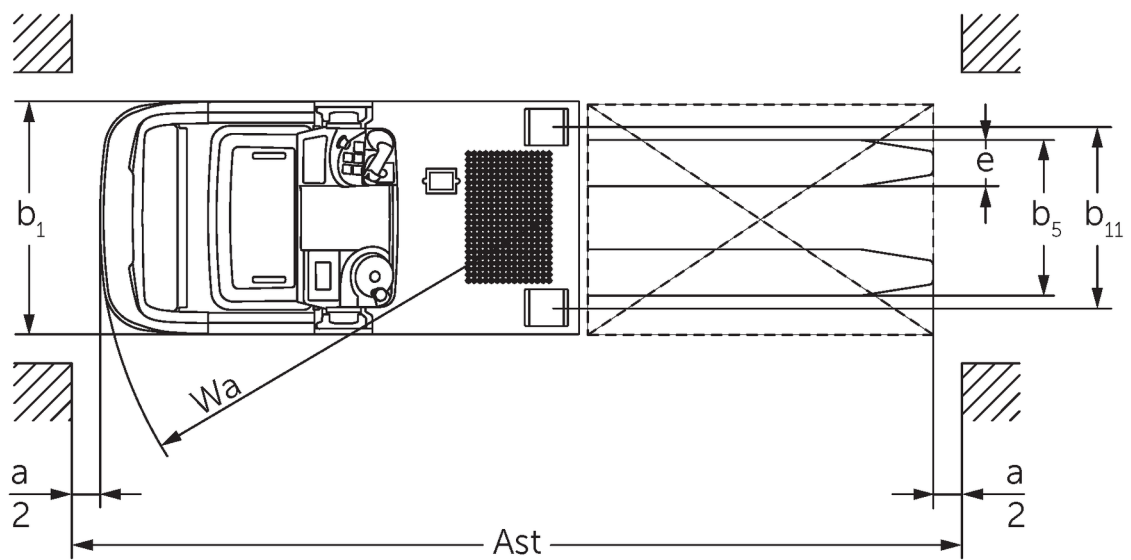
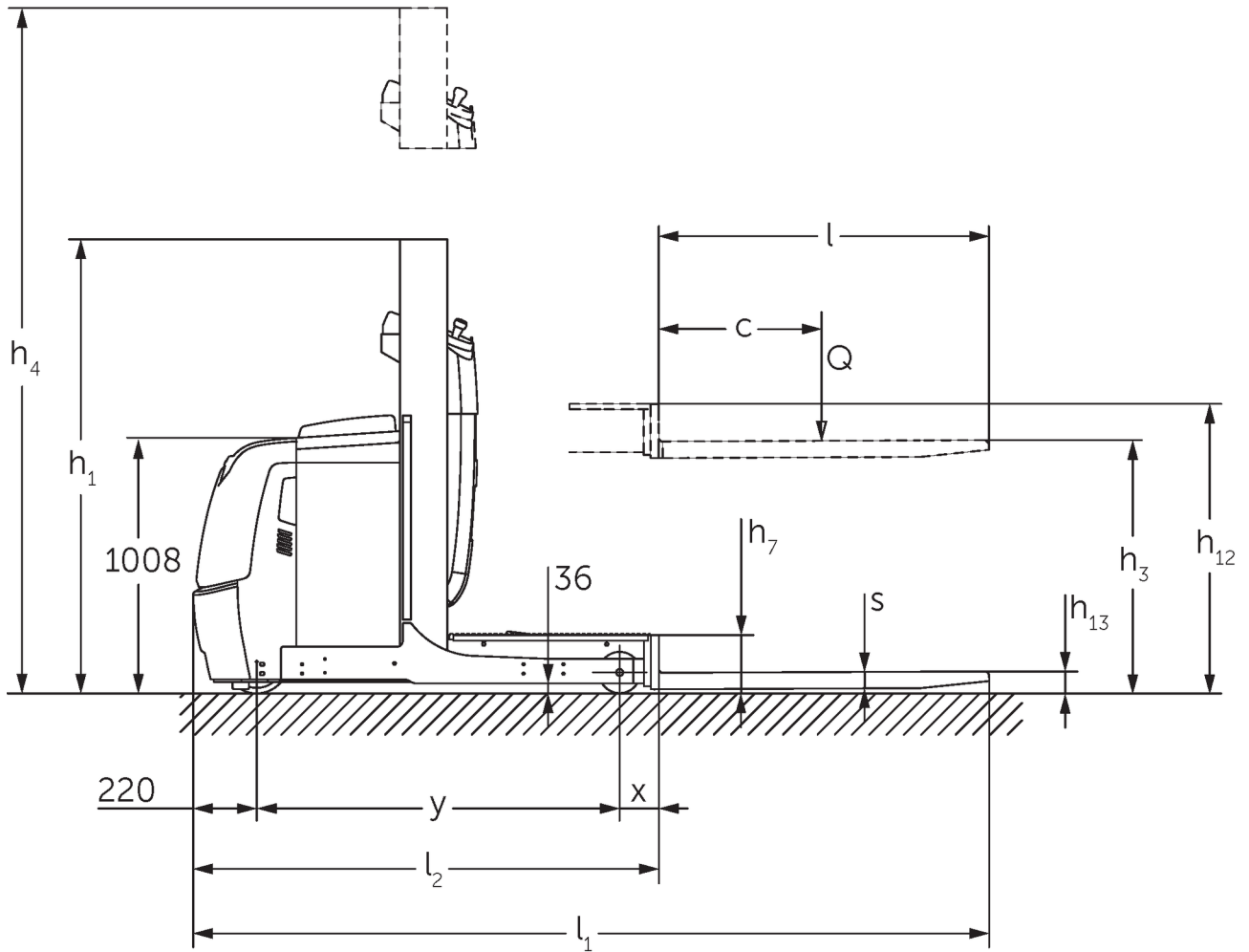

Figure shows EKS 110 Z 280 ZZ

EKS 110



Picture shows EKS 110 L 100 E

VDI table

Stand-on: 08/2022

Characteristic	1.1	Manufacturer (abbreviated description)	Jungheinrich									
			EKS 110 L 100 E	EKS 110 L 160 E	EKS 110 L 190 E	EKS 110 L 280 ZZ	EKS 110 Z 100 E	EKS 110 Z 160 E	EKS 110 Z 190 E	EKS 110 Z 280 ZZ		
Characteristic	1.2	Manufacturer's type designation										
	1.3	Drive	Electric									
	1.4	Operation	Order pickers									
	1.5	Load capacity/load	Q kg	1000								
	1.6	Load centre distance	c mm	600								
	1.8	Load distance, centre of drive axle to fork	x mm	143		180	148		185			
	1.9	Wheelbase	y mm	1330		1385	1330		1385			
	Weights	2.1.1	Service weight (incl. battery)	kg	1661	1785	1813	2268	1763	1907	1953	2390
		2.2	Axle load laden front/rear	kg	491 / 2170	516 / 2269	506 / 2307	762 / 2506	489 / 2274	508 / 2399	504 / 2449	754 / 2636
2.3		Axle load unladen front/rear	kg	1053 / 608	1093 / 692	1084 / 729	1336 / 932	1062 / 701	1083 / 824	1079 / 874	1328 / 1062	
Wheels/suspension system	3.1	Tyres	Vulkollan ®									
	3.2	Tyre size, front	ø 230 x 80									
	3.3	Tyre size, rear	ø 150 x 130									
	3.5	Wheels, number front/back (x=driven)	1x / 2									
	3.7	Tread width, rear	b ₁₁ mm	630		720	630		720			
Basic dimensions	4.2	Retracted mast height (h ₁)	h ₁ mm	1650	2260	2560	2250	1650	2260	2560	2250	
	4.4	Lift (h ₃)	h ₃ mm	1000	1600	1900	2800	1000	1600	1900	2800	
	4.5	Extended mast height (h ₄)	h ₄ mm	2650	3830	4130	5030	2650	3830	4130	5030	
	4.7	Height of overhead guard (cab)	h ₆ mm	-	2230		-	2230				
	4.8.1	Stand height	h ₇ mm	200								
	4.11	Additional lift	h ₉ mm	-				800				
	4.14	Stand height, elevated	h ₁₂ mm	1200	1800	2100	3000	1200	1800	2100	3000	
	4.15	Height, lowered	h ₁₃ mm	80								
	4.19	Overall length	l ₁ mm	2890		2980	2895		2985			
	4.20	Length including fork shank	l ₂ mm	1690		1780	1695		1785			
	4.21.1	Overall width	b ₁ mm	810		900	810		900			
	4.22	Fork dimensions	s/e/l mm	60 x 160 x 1200								
	4.25	Width across forks	b ₅ mm	540								
	4.26	Width between support arms/loading areas	b ₄ mm	430		520	430		520			
	4.27	Width over guide rollers	b ₆ mm	970		1060	970		1060			
	4.31	Ground clearance laden under mast	m ₁ mm	35								
	4.34.1	Aisle width (pallet 1000x1200 sideways)	Ast mm	3039		3127	3039		3127			
4.34.2	Aisle width (pallet 800x1200 length)	Ast mm	3149		3240	3154		3245				
4.35	Turning radius	W _a mm	1548		1603	1548		1603				

Performance data	5.1	Travel speed laden/ unladen (Efficiency drivePLUS)	km/h	9 / 10 10 / 13	9 / 9 10 / 12	9 / 9 9 / 11	9 / 10 10 / 13	9 / 9 10 / 12	9 / 9 9 / 11
	5.2	Lift speed laden/unladen	m/s	0.19 / 0.26	0.15 / 0.2	0.23 / 0.31	0.19 / 0.26	0.15 / 0.2	0.23 / 0.31
	5.3	Lowering speed laden/ unladen	m/s	0.24 / 0.24	0.23 / 0.22	0.28 / 0.26	0.24 / 0.24	0.23 / 0.22	0.28 / 0.26
	5.7	Gradeability laden/ unladen	%	5 / 10					
	5.10	Service brake		generative					
	5.11	Parking brake		elektromagnetisches Federspeicherbremsystem					
E-motor/Electronics	6.1	Drive motor, performance S2 60 min	kW	3.2					
	6.2	Lift motor, performance with S3	kW	3	6	3	6		
	6.3	Battery according to DIN 43531/35/36		DIN 43535 B					
	6.4	Battery voltage/nominal capacity	V / Ah	24 / 620					
	6.5	Battery weight	kg	480					
Other	8.1	Type of drive control		AC					
	10.5	Steering version		Electric power steering					
	10.7	Sound level as per EN12053, operator's ear	dB (A)	61					

- This data sheet according to VDI guideline 2198 only states the technical values of the standard truck. Different tyres, other masts, additional equipment etc. may result in different values.

- 4.2: L100E with overhead guard 2230 mm
- 4.5: L100E with overhead guard 3230 mm
- 4.7: L100E and Z100E overhead guard optional
- 5.1: with drivePLUS performance package (Standard: 9 / 9 km/h for all EKS 110 except for EKS 110 E 100: 10 / 10 km/h)

The German production facilities in
Norderstedt, Moosburg and Landsberg
are certified.

ISO 9001
ISO 14001

Jungheinrich fork lift trucks meet
European safety requirements.



 **JUNGHEINRICH**